

# CRD - 57IB Series

## Detail

- Insulated register boot with ceiling radiation damper
- UL Classified - For use in UL 263 wood truss floor/ceiling assemblies rated 1 hour or less
- UL approved for use in L-587 and L-528 and P-556 design
- Incorporates UL 555C evaluated CRD
- 22 gauge one piece frame and blades, 28 gauge box with either 1 1/2" R-6 or 2" R-8 duct liner insulation
- 165°F fusible link (optional 212°F)
- Standard Link (on 4") and Easy Access Link (5" and up)
- Ceramic thermal blanket provided on units with blade areas of greater than 84 sq. in.
- Available in a range of sizes from 4" x 8" x 4" to 16" x 16" x 12"
- Unique approval for Class 0, Class 1 Flex-duct or steel pipe (elbow) connections to achieve "top out" or "side out" configurations

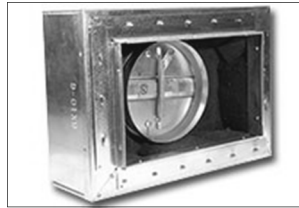

## CONTACT

Office: 888.973.7600

1100 Ashwood Drive  
Suite 1102  
Canonsburg, PA 15317

[www.clward.com](http://www.clward.com)

## Profile

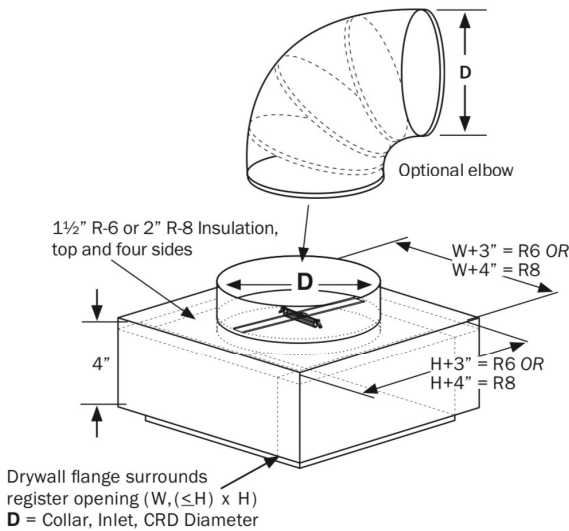

This product meets the requirements for ceiling dampers established by:

**UL Standard 555C**  
**NFPA Standard 90A**  
**ICC Building Codes**

## Item Code Format

5	7	I	B	1	2	0	6	G	0	6	T	4	F
---	---	---	---	---	---	---	---	---	---	---	---	---	---

SERIES: CRD 57      STYLE: IB = Insulated Boot      Damper Width      Damper Height      G = Galvanized 165° Link      Collar Diameter      T4 = R6 Insulation      Flange      R8 = R8 Insulation      F = 5/8" Flange      F1 = 1" Flange



Job Name	
Location	
Architect	
Engineer	
Contractor	